

User's and Service Guide

Agilent Technologies 11645A Series R, Q, U, V, and W Waveguide Verification Kit

This manual applies to the 11645A series calibration devices with serial number prefix 3014A.



Agilent Part Number: 11645-90013

Printed in USA

Print Date: January 2002

Supersedes: August 1995

© Copyright 1995, 2002 Agilent Technologies, Inc. All rights reserved.

Warranty

This product is warranted against defects in material and workmanship for a period of one year from date of shipment. During the warranty period, Agilent Technologies will, at its option, either repair or replace products which prove to be defective.

For warranty service or repair, this product must be returned to a service facility designated by Agilent. Buyer shall prepay shipping charges to Agilent and Agilent shall pay shipping charges to return the product to Buyer. However, Buyer shall pay all shipping charges, duties, and taxes for products returned to Agilent from another country.

Agilent Technologies warrants that its software and firmware designated by Agilent for use with an instrument will execute its programming instructions when properly installed on that instrument. Agilent Technologies does not warrant that the operation of the instrument, or software, or firmware will be uninterrupted or error-free.

Limitation of Warranty

The foregoing warranty shall not apply to defects resulting from improper or inadequate maintenance by Buyer, Buyer-supplied software or interfacing, unauthorized modification or misuse, operation outside of the environmental specifications for the product, or improper site preparation or maintenance.

NO OTHER WARRANTY IS EXPRESSED OR IMPLIED. AGILENT TECHNOLOGIES SPECIFICALLY DISCLAIMS THE IMPLIED WARRANTIES OF MERCHANTABILITY AND FITNESS FOR A PARTICULAR PURPOSE.

Exclusive Remedies

THE REMEDIES PROVIDED HEREIN ARE BUYER'S SOLE AND EXCLUSIVE REMEDIES. AGILENT TECHNOLOGIES SHALL NOT BE LIABLE FOR ANY DIRECT, INDIRECT, SPECIAL, INCIDENTAL, OR CONSEQUENTIAL DAMAGES, WHETHER BASED ON CONTRACT, TORT, OR ANY OTHER LEGAL THEORY.

Assistance

Product maintenance agreements and other customer assistance agreements are available for Agilent products.

For any assistance, contact Agilent Technologies. Refer to [page 5-4](#) for a list of Agilent contacts.

1. General Information	
Verification Kit Overview	1-2
Kit Contents	1-2
Compatible Network Analyzers	1-2
Equipment Required but Not Supplied	1-3
Incoming Inspection	1-3
Recording the Device Serial Numbers	1-4
Preventive Maintenance	1-4
2. Specifications	
Environmental Requirements	2-2
Temperature—What To Watch Out For	2-2
Electrical Specifications	2-3
Certification	2-3
3. Use, Maintenance, and Care of the Devices	
Electrostatic Discharge	3-6
Visual Inspection	3-7
What Causes Mating Surface Wear?	3-7
Inspect the Mating Plane Surfaces	3-7
Cleaning the Mating Plane Surfaces	3-8
Connections	3-9
Connecting Waveguide Devices	3-9
How to Connect: R-band WR-28	3-9
How to Connect:	
Q-band WR-22	
U-band WR-19	
V-band WR-15	
W-band WR-10	3-10
Handling and Storage	3-11
4. Performance Verification	
Introduction	4-2
How Agilent Verifies the Devices in Your Kit	4-2
Recertification	4-3
How Often to Recertify	4-3
Where to Send a Kit for Recertification	4-3
5. Troubleshooting	
Troubleshooting Process	5-2
Returning a Kit or Device to Agilent Technologies	5-4
Where to Look for More Information	5-4
Contacting Agilent	5-4
6. Replaceable Parts	
Introduction	6-2

1 General Information

Verification Kit Overview

The following verification kits provide a set of standards with known characteristics, traceable to a reference (golden) standard in Agilent Technologies calibration lab. The sets of standards are used to verify your measurement calibration and also to verify that your network analyzer system is operating within its specifications.

NOTE A file containing the verification data for your kit is maintained for one year from the time of measurement. If you lose this data, contact Agilent. See [“Contacting Agilent” on page 5-4](#) for a list of telephone numbers.

Kit Contents

The 11645A verification kit includes the following items:

- 20 dB attenuator
- 50 dB attenuator
- 25Ω mismatch airline
- 50Ω airline
- data disks that contain factory-measured verification data of the devices in the verification kit

NOTE A backup copy of each verification data disk should be made immediately upon receipt of the this kit. Refer to your analyzers user’s guide for instructions on duplicating a disk.

Refer to [Chapter 6, “Replaceable Parts”](#) for a complete list of kit contents and their associated part numbers.

Compatible Network Analyzers

Each verification kit is intended to be used with a respective R, Q, U, V, or W11644A calibration kit and any of the following Agilent Technologies network analyzers:

- 8510 Series
- 85106
- 872x Series
- PNA Microwave Series

The verification data disk provided for use with each of the network analyzers listed above contains the factory-measured S-parameter data for the devices in this kit. It also contains the uncertainty limits used in the system verification procedure. This data is unique to each kit.

Equipment Required but Not Supplied

Cleaning supplies and various electrostatic discharge (ESD) protection devices are not supplied with the calibration kit but are required to ensure successful operation of the kit. Refer to [Table 6-6 on page 6-12](#) for ordering information.

Incoming Inspection

Verify that the shipment is complete by referring to the appropriate parts tables in [Chapter 6](#). Use [Table 1-1](#) to record the serial numbers of all serialized devices in your kit.

Check for damage. The foam-lined storage case provides protection during shipping. Verify that this case and its contents are not damaged.

If the case or any device appears damaged, or if the shipment is incomplete, refer to [“Contacting Agilent” on page 5-4](#). Agilent will arrange for repair or replacement of incomplete or damaged shipments without waiting for a settlement from the transportation company. Refer to [“Returning a Kit or Device to Agilent Technologies” on page 5-4](#) for instructions.

Recording the Device Serial Numbers

In addition to the kit serial number, the devices in this kit are individually serialized (serial numbers are labeled into the body of each device). Record these serial numbers in the appropriate table. Recording the serial numbers will prevent confusing the devices in this kit with similar devices from other kits.

Table 1-1 Serial Number Record

Device	Serial Number
Frequency band	_____
Verification kit	_____
20 dB attenuator	_____
40 dB attenuator	_____
50Ω airline	_____
25Ω mismatch airline	_____

Preventive Maintenance

The best techniques for maintaining the integrity of the devices in this kit include:

- routine visual inspection
- routine cleaning
- proper connection techniques

All of these are described in [Chapter 3](#). Failure to detect and remove dirt or metallic particles can degrade repeatability and accuracy and can damage any mating surface connected to it. Improper connections can also damage these devices.

2 Specifications

Environmental Requirements

Table 2-1 Environmental Requirements

Parameter	Required Values/Ranges
Temperature	
Operating ^a	+20 °C to +26 °C (+68 °F to +79 °F)
Error-corrected range ^b	±1 °C (1.8 °F) of measurement calibration temperature
Altitude	
Operating	< 4,500 meters (≈15,000 feet)
Storage	< 15,000 meters (≈50,000 feet)
Relative humidity	Always non-condensing
Operating	0 to 80% (26 °C maximum dry bulb)
Storage	0 to 90%

- a. The temperature range over which the calibration standards maintain conformance to their specifications.
- b. The allowable network analyzer ambient temperature drift during measurement calibration and during measurements when the network analyzer error correction is turned on. Also, the range over which the network analyzer maintains its specified performance while correction is turned on.

Temperature—What To Watch Out For

Due to the small dimensions of the devices, electrical characteristics will change with temperature. Therefore, the operating temperature is a critical factor in their performance, and must be stable before use.

IMPORTANT Avoid unnecessary handling of the devices during use because your fingers act as a heat source and may increase the temperature of the device.

Electrical Specifications

At the factory, each verification device is electrically characterized on a network analyzer measurement system. These factory measurements are traceable to the National Institute of Standards and Technology (NIST) through mechanical and electrical paths. For more information on traceability, contact Agilent Technologies. Refer to [page 5-4](#) for a list of Agilent contacts.

Two pieces of information constitute the standard electrical specification of a verification device:

- the S-parameter measurement data for the device
- the measurement uncertainties of the system on which the device was measured

The factory-measured data for each device is supplied with your kit in print form, and on disk.

Certification

Agilent Technologies certifies that this product met its published specifications at the time of shipment from the factory. Agilent further certifies that its calibration measurements are traceable to the United States National Institute of Standards and Technology (NIST) to the extent allowed by the institute's calibration facility, and to the calibration facilities of other International Standards Organization members. See "[How Agilent Verifies the Devices in Your Kit](#)" on [page 4-2](#) for more information.

3 Use, Maintenance, and Care of the Devices

Electrostatic Discharge

Protection against electrostatic discharge (ESD) is essential while connecting, inspecting, or cleaning connectors attached to a static-sensitive circuit (such as those found in test sets).

Static electricity can build up on your body and can easily damage sensitive internal circuit elements when discharged. Static discharges too small to be felt can cause permanent damage. Devices such as calibration components and devices under test (DUT), can also carry an electrostatic charge. To prevent damage to the test set, components, and devices:

- *Always* wear a grounded wrist strap having a 1 M Ω resistor in series with it when handling components and devices or when making connections to the test set.
- *Always* use a grounded, conductive table mat while making connections.
- *Always* wear a heel strap when working in an area with a conductive floor. If you are uncertain about the conductivity of your floor, wear a heel strap.

Figure 3-1 shows a typical ESD protection setup using a grounded mat and a wrist strap. Refer to Table 6-6 on page 6-12 for information on ordering supplies for ESD protection.

Figure 3-1 ESD Protection Setup

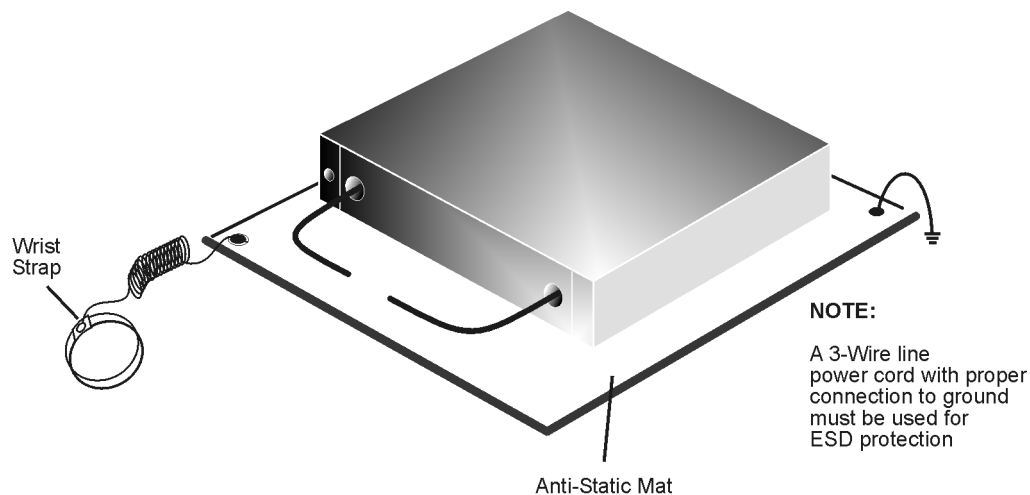

ku310b

Visual Inspection

Examine the mating surfaces first for obvious defects or damage. If necessary, cleaning should be done every time a connection is made. Metal particles or dirt may fall onto the mating surface during the connection and disconnection process.

CAUTION Devices with damaged mating surfaces should be immediately discarded or clearly marked and set aside for repair. A damaged device will in turn damage any good device to which it is attached. Determine the cause of the damage before connecting a new, undamaged device in the same configuration.

In some cases, magnification is necessary to see damage; a magnifying device with a magnification of $\geq 10\times$ is recommended. However, not all defects that are visible only under magnification will affect the electrical performance of the device. Use the following guidelines when evaluating the integrity of a connection.

What Causes Mating Surface Wear?

Mating surface wear is caused by connecting and disconnecting the devices. The more use a device gets, the faster it wears and degrades. The wear is greatly accelerated when mating surfaces are not kept clean, or are not connected properly.

Mating surface wear eventually degrades performance of the device. Calibration devices should have a long life if their use is on the order of a few times per week. Replace devices with worn mating surfaces.

The test port connectors on the network analyzer test set may have many connections each day, and are, therefore, more subject to wear. It is recommended that an adapter be used as a test port saver to minimize the wear on the test set's test port connectors.

Inspect the Mating Plane Surfaces

Flat contact between the mating plane surfaces is required for a good connection. Look especially for deep scratches or dents, and for dirt and metal particles on the mating plane surfaces. Also look for signs of damage due to excessive or uneven wear or misalignment.

Light burnishing of the mating plane surfaces is normal, and is evident as light scratches or shallow marks distributed more or less uniformly over the mating plane surface. Other small defects and cosmetic imperfections are also normal. None of these affect electrical or mechanical performance. If a mating surface shows deep scratches or dents, clinging particles, or uneven wear, clean and inspect it again.

Cleaning the Mating Plane Surfaces

1. Use Compressed Air or Nitrogen

Clean mating surfaces are essential for ensuring the integrity of the waveguide.

WARNING Always use protective eyewear when using compressed air or nitrogen.

Use compressed air (or nitrogen) to loosen particles on the mating plane surfaces.

You can use any source of clean, dry, low-pressure compressed air or nitrogen that has an effective oil-vapor filter and liquid condensation trap placed before the outlet hose.

Ground the hose nozzle to prevent electrostatic discharge, and set the air pressure to less than 414 kPa (60 psi) to control the velocity of the air stream. High-velocity streams of compressed air can cause electrostatic effects when directed into a device. These electrostatic effects can damage the device. Refer to [“Electrostatic Discharge” on page 3-6](#) for additional information.

WARNING Keep isopropyl alcohol away from heat, sparks, and flame. Store in a tightly closed container. It is extremely flammable. In case of fire, use alcohol foam, dry chemical, or carbon dioxide; water may be ineffective.

Use isopropyl alcohol with adequate ventilation and avoid contact with eyes, skin, and clothing. It causes skin irritation, may cause eye damage, and is harmful if swallowed or inhaled. It may be harmful if absorbed through the skin. Wash thoroughly after handling.

In case of spill, soak up with sand or earth. Flush spill area with water.

Dispose of isopropyl alcohol in accordance with all applicable federal, state, and local environmental regulations.

2. Clean the Mating Plane Surfaces

- a. Apply a small amount of isopropyl alcohol to a lint-free cleaning swab.
- b. Clean the mating plane surfaces.
- c. Let the alcohol evaporate, then blow the surface dry with a gentle stream of clean, low-pressure compressed air or nitrogen. Always completely dry the surfaces before you use it.

3. Inspect the Mating Surfaces

Inspect the mating surface to make sure that no particles or residue remain. Refer to [“Visual Inspection” on page 3-7](#).

Connections

Good connections require a skilled operator. Instrument sensitivity and mechanical tolerances are such that slight errors in operator technique can have a significant effect on measurements and measurement uncertainties. *The most common cause of measurement error is bad connections.*

Connecting Waveguide Devices

IMPORTANT Unlike threaded devices, the WR-28, WR-22, WR-19, WR-15, and WR-10 waveguide mating planes are flanges (often precision) that you must carefully screw together. Always connect waveguide in the same flange orientation. For example, use the label as a reference and always connect a device with the label facing the same direction.

The following procedures illustrate how to make good connections.

How to Connect: R-band WR-28

Always connect the waveguide with the same flange orientation. For example, always connect a device with the label facing the same direction.

Follow these recommendations for optimum connection technique:

1. Place two alignment pins (with heads) in opposite holes of each flange. For example, one in the top left, and one in the bottom right.
2. Using the pins as guides, carefully align the flanges, and insert screws in the two open corner holes.
3. Place a lock washer and nut on each screw, and finger tighten.
4. Remove the alignment pins and insert the remaining two screws.
5. Place a lock washer and nut on each screw, and finger tighten.
6. Inspect each lock washer to be sure they are similarly compressed.
7. In an X pattern (for equal compression), use the hex ball driver to tighten all four screws. *Do not over-tighten.*

NOTE Apply symmetrical pressure as you gradually tighten the screws.

8. Visually inspect the connection:
 - a. Place an electric light or white paper behind the connection.

Connections

- b. Check the flange matings for any gap. A good connection has no gaps between the connected waveguide flanges, and the waveguide walls are flush (there is no step or offset).
- c. Inspect the washers for symmetrical compression. This ensures that all four screws are equally torqued.

How to Connect:

Q-band WR-22

U-band WR-19

V-band WR-15

W-band WR-10

To ensure proper flange mating, each device has two attached alignment pins, and two alignment holes through which you slide additional pins. You don't have to use nuts or washers when connecting Q, U, V, or W-band waveguide. The flanges have tapped screw holes; captive screws (threaded half-way up the shaft) are provided in these kits.

Follow these recommendation for optimum connection technique:

1. Install four captive screws into the test port.
2. Install the alignment pins.
3. Using the pins as a guide, bring the flanges together and gently engage the first few threads of each screw.
4. In an X pattern (for equal compression), use the hex ball driver to tighten all four screws. *Do not over-tighten.*
5. Visually inspect the connection:
 - a. Place an electric light or white paper behind the connection.
 - b. Check the flange mating for any gap. A good connection has no gaps between the connected waveguide flanges, and the waveguide walls are flush (there is no step or offset).

Handling and Storage

- *Do* install the protective end caps over the mating surfaces and store the devices in the foam-lined storage case when not in use.
- *Do* keep devices clean.
- *Do not* store devices loose in a box, or in a desk or bench drawer. This is the most common cause of damage during storage.
- *Do not* touch mating plane surfaces. Natural skin oils and microscopic particles of dirt are easily transferred to a the interface and are very difficult to remove.
- *Do not* set devices contact-end down on a hard surface. The plating and the mating plane surfaces can be damaged if the interface comes in contact with any hard surface.

4 Performance Verification

Introduction

The performance of your verification kit can only be verified by returning the kit to Agilent Technologies for recertification. The equipment and calibration standards required to verify the specifications of the devices in the kit have been specially manufactured and are not commercially available.

How Agilent Verifies the Devices in Your Kit

Agilent verifies the specifications of these devices as follows:

1. The residual microwave error terms of the test system are verified with precision airlines and shorts that are directly traced to the National Institute of Standards and Technology (NIST). The airline and short characteristics are developed from mechanical measurements. The mechanical measurements and material properties are carefully modeled to give very accurate electrical representation. The mechanical measurements are then traced to NIST through various plug and ring gages and other mechanical measurements.
2. Each device is electrically tested on this system. For the initial (before sale) testing of the devices, Agilent includes the test measurement uncertainty as a guardband to guarantee each device meets the published specification. For recertifications (after sale), no guardband is used and the measured data is compared directly with the specification to determine the pass or fail status. The measurement uncertainty for each device is, however, recorded in the calibration report that accompanies recertified kits.

These two steps establish a traceable link to NIST for Agilent to the extent allowed by the institute's calibration facility. The specifications data provided for the devices in the kit is traceable to NIST through Agilent Technologies.

Recertification

The following will be provided with a recertified kit:

- a new calibration sticker affixed to the case
- a certificate of calibration
- a calibration report for each device in the kit listing measured values, specifications, and uncertainties

NOTE A list of NIST traceable numbers may be purchased upon request to be included in the calibration report.

Agilent Technologies offers a *Standard* calibration for the recertification of the kit. For more information, contact Agilent Technologies. Refer to [“Contacting Agilent” on page 5-4](#) for a list of offices.

How Often to Recertify

The suggested initial interval for recertification is 12 months or sooner. The actual need for recertification depends on the use of the kit. After reviewing the results of the initial recertification, you may establish a different recertification interval that reflects the usage and wear of the kit.

NOTE The recertification interval should begin on the date the kit is *first used* after the recertification date.

Where to Send a Kit for Recertification

Contact Agilent Technologies for information on where to send your kit for recertification. Contact information is listed on [page 5-4](#). Refer to [“Returning a Kit or Device to Agilent Technologies” on page 5-4](#) for details on sending your kit.

5 Troubleshooting

Troubleshooting Process

This manual contains limited information about network analyzer system operation. For complete information, refer to the instrument documentation.

If your network analyzer does not pass performance verification, follow the steps in [Figure 5-1](#) to determine the cause of the failure and the correct action to take to correct the failure.

Figure 5-1 Troubleshooting Flowchart

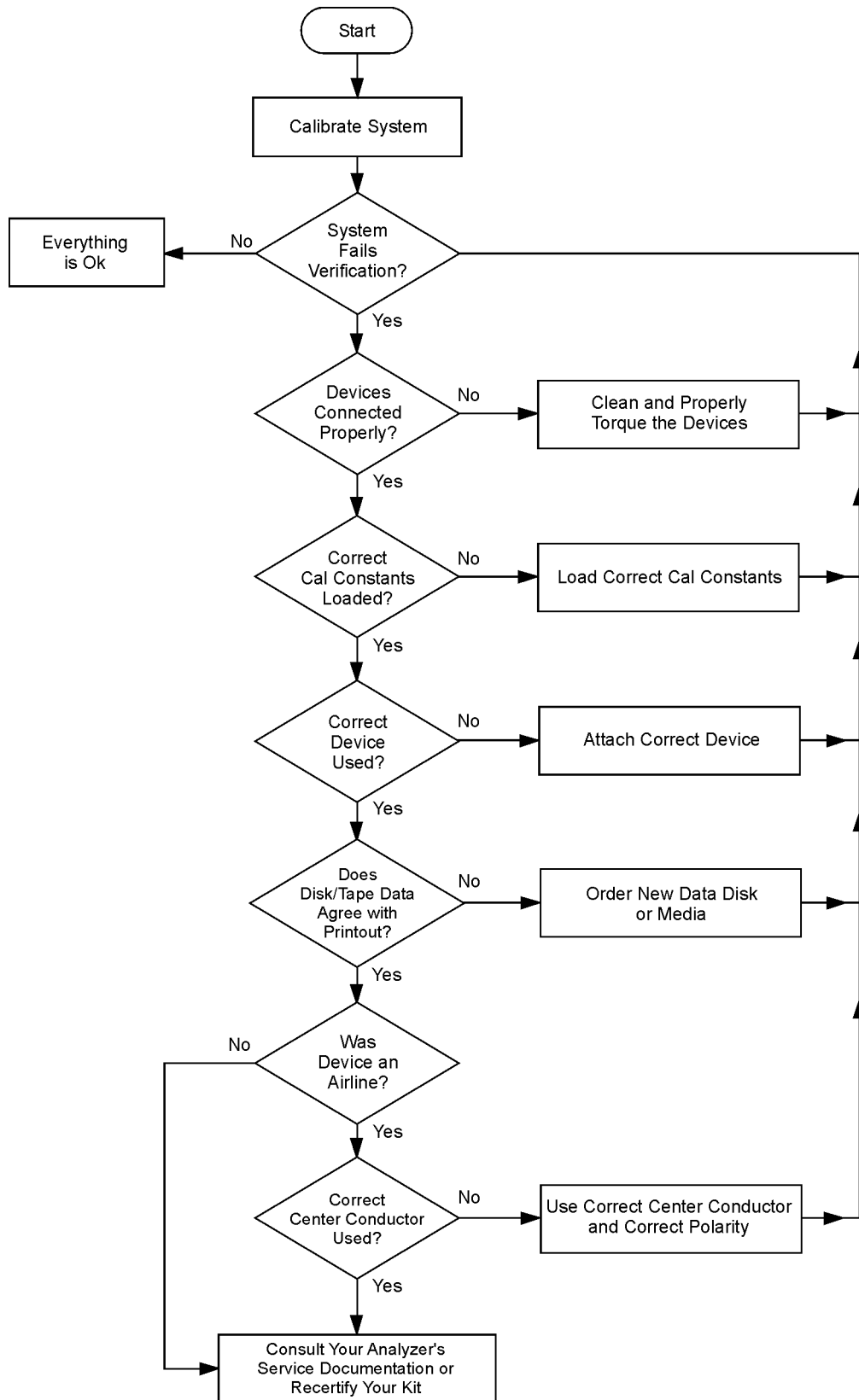

xd904a

Returning a Kit or Device to Agilent Technologies

If your kit or device requires service, contact Agilent Technologies for information on where to send it. See [Table 5-1](#) for contact information. Include a service tag (located at the back of this manual) on which you provide the following information:

- your company name and address
- a technical contact person within your company, and the person's complete telephone number including country code and area code
- the model number and serial number of the kit (if returning a complete kit)
- the part number and serial number of each device being returned
- the type of service required
- a *detailed* description of the problem (if applicable) and how the device was being used when the problem occurred

Where to Look for More Information

This manual contains limited information about network analyzer system operation. For complete information, refer to the instrument documentation. If you need additional information, contact Agilent Technologies.

Contacting Agilent

Table 5-1 Contacting Agilent

Online assistance: www.agilent.com/find/assist			
United States <i>(tel)</i> 1 800 452 4844	Latin America <i>(tel)</i> (305) 269 7500 <i>(fax)</i> (305) 269 7599	Canada <i>(tel)</i> 1 877 894 4414 <i>(fax)</i> (905) 282-6495	Europe <i>(tel)</i> (+31) 20 547 2323 <i>(fax)</i> (+31) 20 547 2390
New Zealand <i>(tel)</i> 0 800 738 378 <i>(fax)</i> (+64) 4 495 8950	Japan <i>(tel)</i> (+81) 426 56 7832 <i>(fax)</i> (+81) 426 56 7840	Australia <i>(tel)</i> 1 800 629 485 <i>(fax)</i> (+61) 3 9210 5947	Singapore <i>(tel)</i> 1 800 375 8100 <i>(fax)</i> (65) 836 0252
Malaysia <i>(tel)</i> 1 800 828 848 <i>(fax)</i> 1 800 801 664	Philippines <i>(tel)</i> (632) 8426802 <i>(tel) (PLDT subscriber only):</i> 1 800 16510170 <i>(fax)</i> (632) 8426809 <i>(fax) (PLDT subscriber only):</i> 1 800 16510288	Thailand <i>(tel) outside Bangkok:</i> (088) 226 008 <i>(tel) within Bangkok:</i> (662) 661 3999 <i>(fax)</i> (66) 1 661 3714	Hong Kong <i>(tel)</i> 800 930 871 <i>(fax)</i> (852) 2506 9233
Taiwan <i>(tel)</i> 0800-047-866 <i>(fax)</i> (886) 2 25456723	People's Republic of China <i>(tel) (preferred):</i> 800-810-0189 <i>(tel) (alternate):</i> 10800-650-0021 <i>(fax)</i> 10800-650-0121	India <i>(tel)</i> 1-600-11-2929 <i>(fax)</i> 000-800-650-1101	

6 Replaceable Parts

Introduction

The following tables list the replacement part numbers for the Agilent R11645A, Q11645A, U11645A, V11645A, and W11645A waveguide calibration kit contents. [Table 6-6](#) lists the replacement part numbers for items *not* included in the calibration kit that are either required or recommended for successful operation of the kit.

To order a listed part, note the description, the part number, and the quantity desired. Telephone or send your order to Agilent Technologies. Refer to [“Contacting Agilent” on page 5-4](#) for further information.

Table 6-1 Replaceable Parts for the R11645A WR-28

Description	Qty Per Kit	Agilent Part Number
Attenuators		
20 dB attenuator with data	1	11645-60021
50 dB attenuator with data	1	11645-60022
Airlines		
50Ω airline with data	1	11645-60016
25Ω mismatch airline with data	1	11645-60011
Miscellaneous Items		
Disk holder	1	5180-8491
Pad	1	11645-80026
Storage case	1	5181-5517
Storage box assembly	1	1540-0034
User's and service guide	1	11645-90013
Verification data disk (R)	1	11645-60026
Verification data disk (PNA)	1	11645-10018
Specification and performance verification disk	1	08510-10033
Connector care—quick reference card	1	08510-90360
Hardware		
Lock Washer	6	2190-0030
Hex Nut	6	2260-0002
Waveguide Alignment Pin (short)	6	11644-20009
Waveguide Alignment Pin (long)	6	11644-20006
4-40 Hex ball screw (0.75 inches)	6	3030-0721
3/32-inch hex ball driver	1	8710-1539

Figure 6-1 R-Band Component Identification Sheet

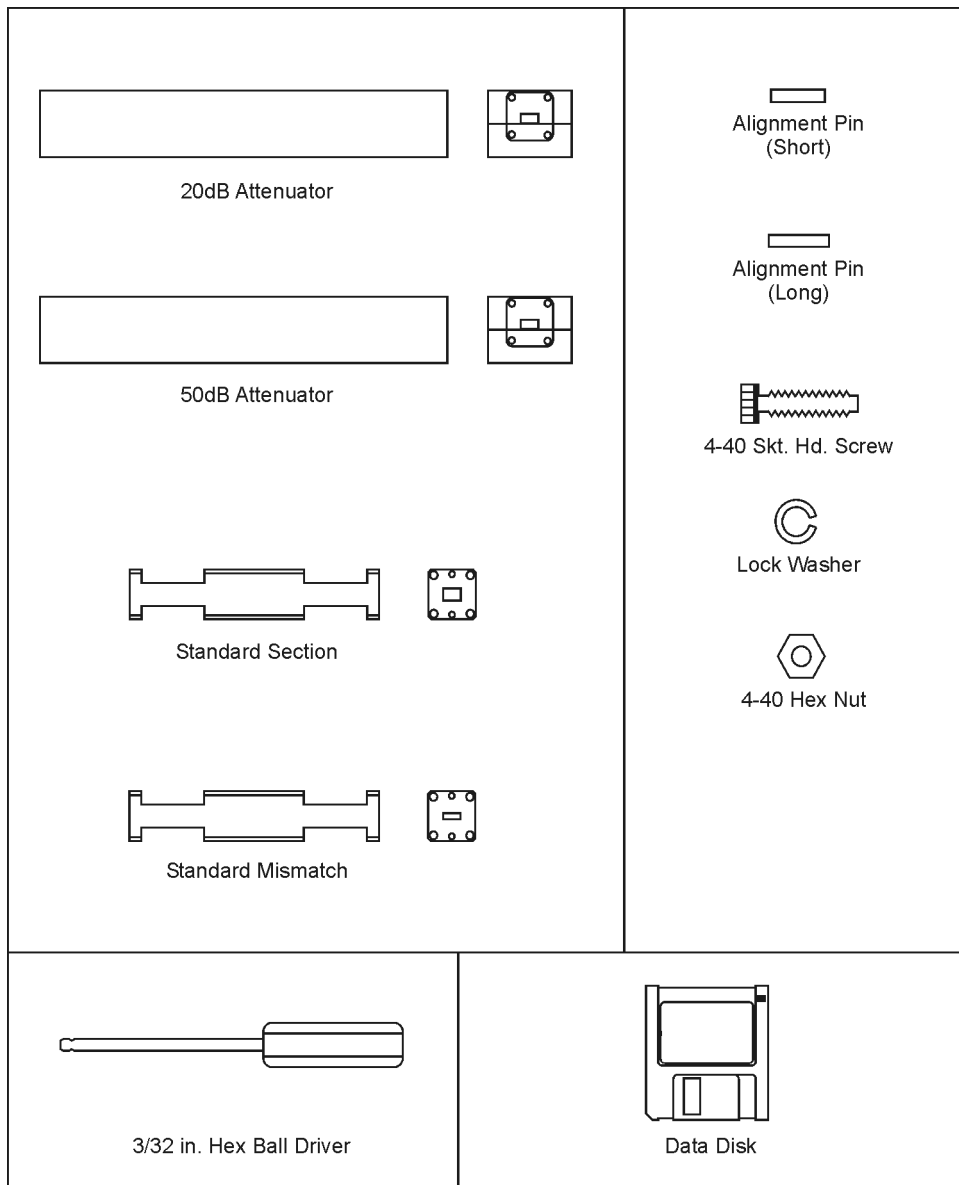

xd901a

Table 6-2 Replaceable Parts for the Q11645A WR-22

Description	Qty Per Kit	Agilent Part Number
Attenuators		
20 dB attenuator with data	1	11645-60023
50 dB attenuator with data	1	11645-60024
Airlines		
50Ω airline with data	1	11645-60017
25Ω mismatch airline with data	1	11645-60012
Miscellaneous Items		
Disk holder	1	5180-8491
Pad	1	11645-80027
Storage case	1	5181-5517
Storage box assembly	1	1540-0034
User's and service guide	1	11645-90013
Verification data disk (Q)	1	11645-60027
Verification data disk (PNA)	1	11645-10017
Specification and performance verification disk	1	08510-10033
Connector care—quick reference card	1	08510-90360
Hardware		
Waveguide Alignment Pin (short)	6	11644-20008
Waveguide Alignment Pin (long)	6	11644-20006
4-40 Hex ball screw (0.31 inches)	6	1390-0671
4-40 Hex ball screw (0.43 inches)	6	1390-0764
3/32-inch hex ball driver	1	8710-1539

Figure 6-2 Q-Band Component Identification Sheet

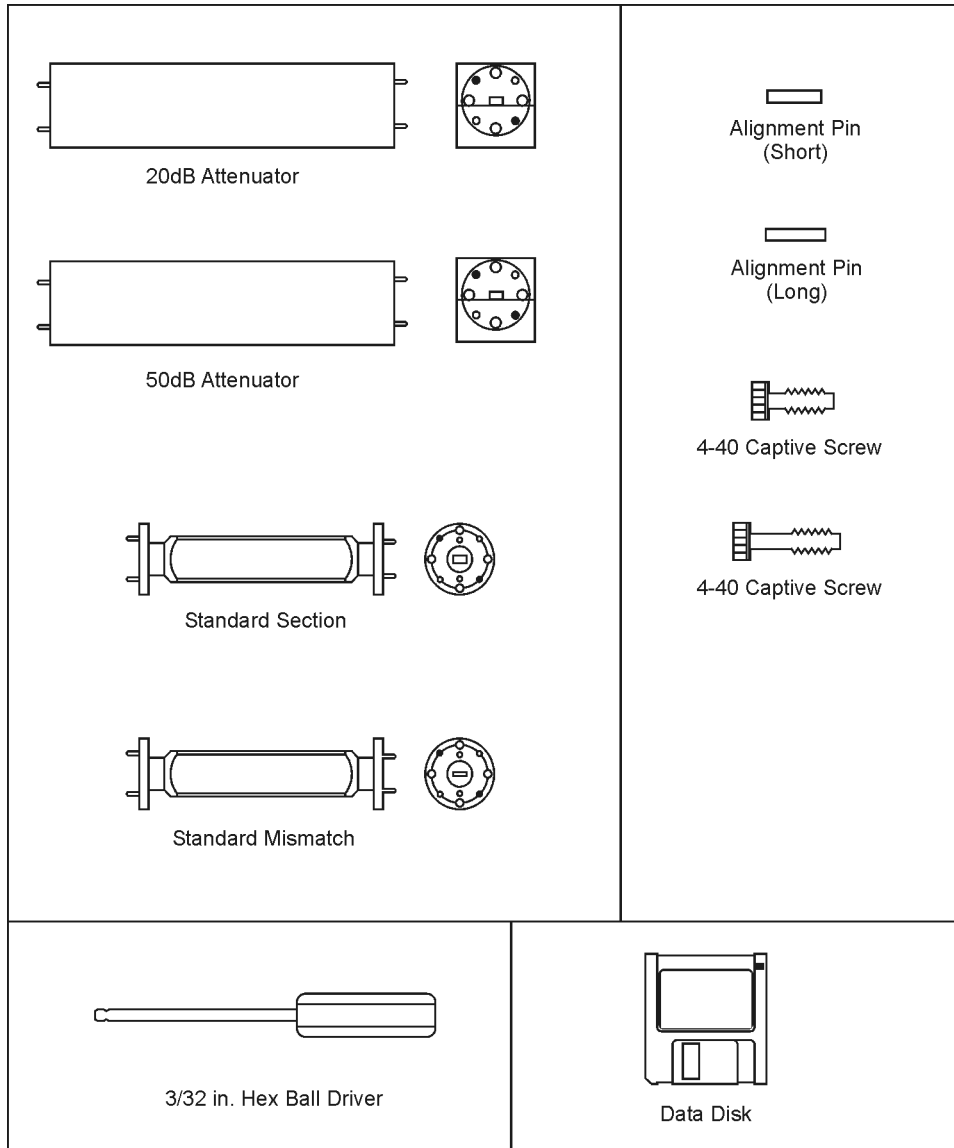

xd902a

Table 6-3 Replaceable Parts for the U11645A WR-19

Description	Qty Per Kit	Agilent Part Number
Attenuators		
20 dB attenuator with data	1	11645-60025
50 dB attenuator with data	1	11645-60006
Airlines		
50Ω airline with data	1	11645-60018
25Ω mismatch airline with data	1	11645-60013
Miscellaneous Items		
Disk holder	1	5180-8491
Pad	1	11645-80027
Storage case	1	5181-5517
Storage box assembly	1	1540-0034
User's and service guide	1	11645-90013
Verification data disk (U)	1	11645-60028
Specification and performance verification disk	1	08510-10033
Connector care—quick reference card	1	08510-90360
Hardware		
Waveguide Alignment Pin (short)	6	11644-20008
Waveguide Alignment Pin (long)	6	11644-20006
4-40 Hex ball screw (0.31 inches)	6	1390-0671
4-40 Hex ball screw (0.43 inches)	6	1390-0764
3/32-inch hex ball driver	1	8710-1539

Figure 6-3 U-Band Component Identification Sheet

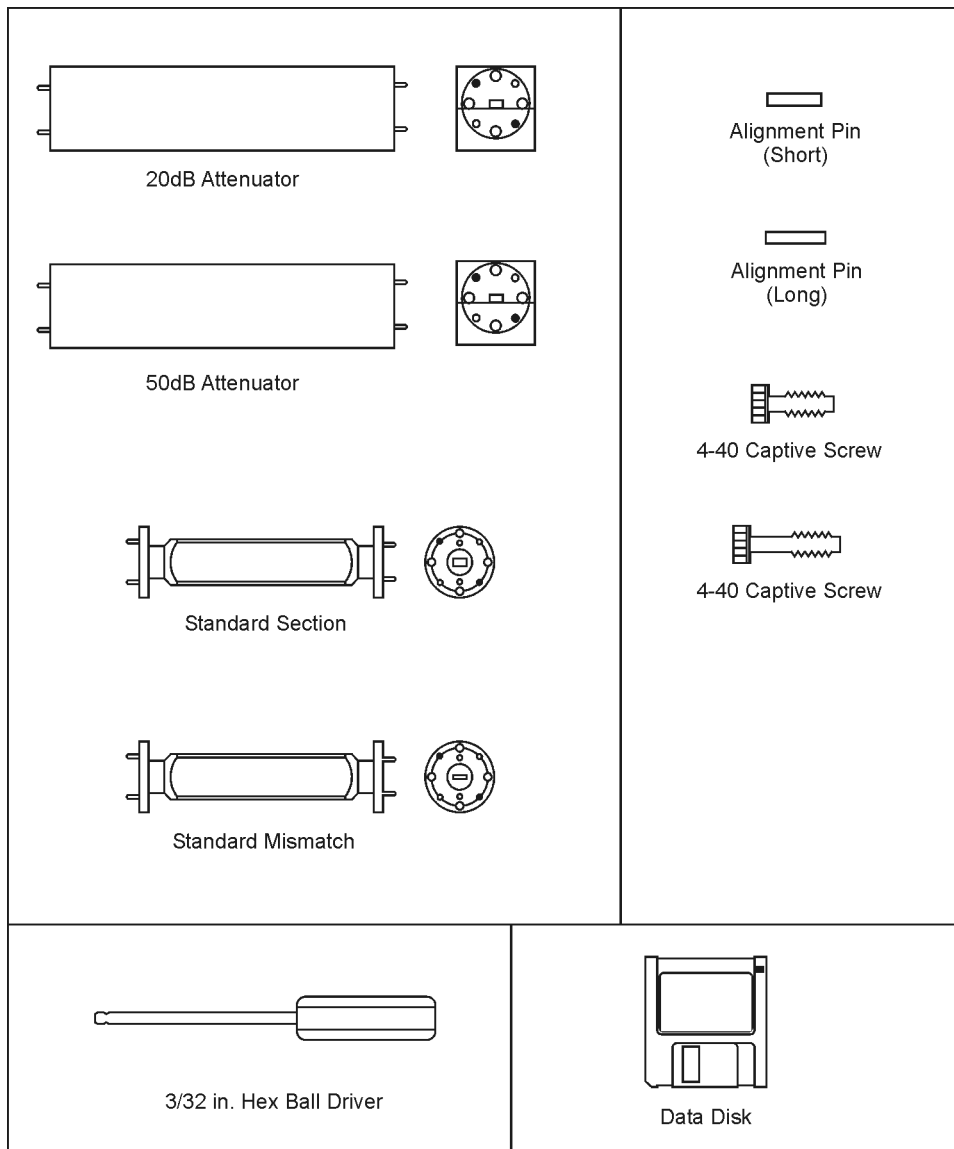

xd902a

Table 6-4 Replaceable Parts for the V11645A WR-15

Description	Qty Per Kit	Agilent Part Number
Attenuators		
20 dB attenuator with data	1	11645-60007
50 dB attenuator with data	1	11645-60008
Airlines		
50Ω airline with data	1	11645-60019
25Ω mismatch airline with data	1	11645-60014
Miscellaneous Items		
Disk Holder	1	5180-8491
Pad	1	11645-80028
Storage case	1	5181-5517
Storage box assembly	1	1540-0034
User's and service guide	1	11645-90013
Verification data disk (V)	1	11645-60029
Specification and performance verification disk	1	08510-10033
Connector care—quick reference card	1	08510-90360
Hardware		
Waveguide Alignment Pin V/W	6	11644-20007
4-40 Hex ball screw (0.31 inches)	6	1390-0671
4-40 Hex ball screw (0.41 inches)	6	1390-0765
3/32-inch hex ball driver	1	8710-1539

Figure 6-4 V-Band Component Identification Sheet

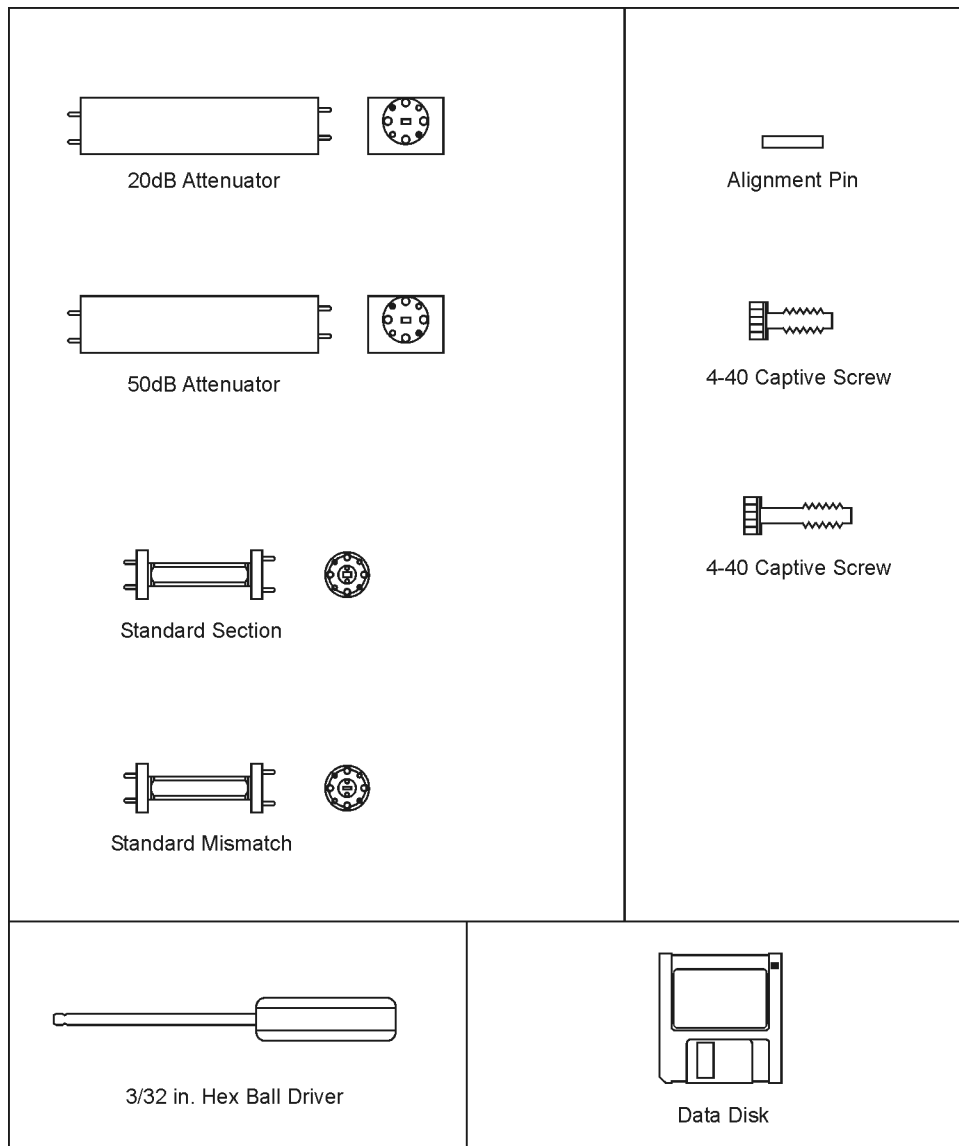

xd903a

Table 6-5 Replaceable Parts for the W11645A WR-10

Description	Qty Per Kit	Agilent Part Number
Attenuators		
20 dB attenuator with data	1	11645-60009
50 dB attenuator with data	1	11645-60010
Airlines		
50Ω airline with data	1	11645-60020
25Ω mismatch airline with data	1	11645-60015
Miscellaneous Items		
Disk holder	1	5180-8491
Pad	1	11645-80028
Storage case	1	5181-5517
Storage box assembly	1	1540-0034
User's and service guide	1	11645-90013
Verification data disk (W)	1	11645-60030
Specification and performance verification disk	1	08510-10033
Connector care—quick reference card	1	08510-90360
Hardware		
Waveguide Alignment Pin V/W	6	11644-20007
4-40 Hex ball screw (0.31 inches)	6	1390-0671
4-40 Hex ball screw (0.41 inches)	6	1390-0765
3/32-inch hex ball driver	1	8710-1539

Figure 6-5 W-Band Component Identification Sheet

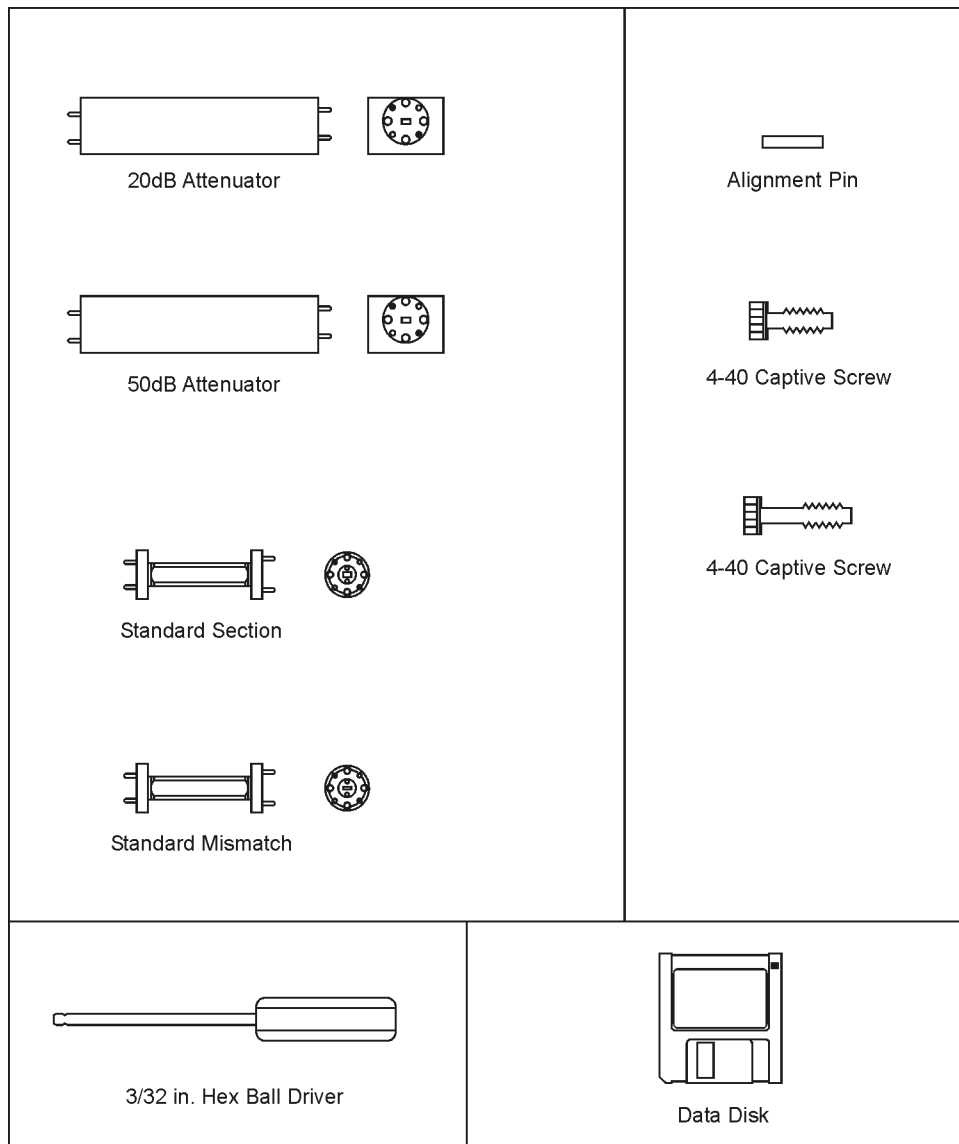

xd903a

Table 6-6 Items Not Included in the Verification Kit

Description	Qty	Agilent Part Number
ESD Protection Devices		
Grounding wrist strap	1	9300-1367
5 ft grounding cord for wrist strap	1	9300-0980
2 x 4 ft conductive table mat and 15 ft ground wire	1	9300-0797
ESD heel strap (for conductive floors)	1	9300-1308
Connector Cleaning Supplies		
Isopropyl alcohol	30 ml	8500-5344
Cleaning swabs	100	9301-1243

A

Agilent Technologies
 contacting, 5-4
agreements
 warranty, ii
airline, part numbers, 6-2, 6-4,
 6-8, 6-10
alcohol, isopropyl
 precautions for use of, 3-8
altitude, specifications, 2-2
assistance
 contacting agilent, 5-4
 who to contact, ii
attenuator, part numbers, 6-2,
 6-4, 6-6, 6-8, 6-10

B

box, part number, 6-2, 6-4, 6-6,
 6-8, 6-10

C

calibration kit
 contents, 1-2
 misuse of product, ii
 overview, 1-2
 verifying devices, 4-3
calibration, certificate of, 4-3
case
 storage, part number, 6-2, 6-4,
 6-6, 6-8, 6-10
certificate of calibration, 4-3
certification, device specifications,
 2-3
cleaning
 mating plane surfaces, 3-8
 supplies, 1-3
 part number, 6-12
compatible network analyzers,
 1-2
compressed air or nitrogen, 3-8
conductive table mat
 for ESD protection, 3-6
 part number, 6-12
connecting
 ESD protection, 3-6
 waveguides, 3-9
 (Q, U, V, and W), 3-10
 (R-band), 3-9
connector
 visual inspection, 3-7
 wear, 3-7
contacting Agilent Technologies,
 5-4
contents
 drawing of, 6-3, 6-6, 6-8
 verification kit, 1-2, 6-3

cord

 grounding, part number, 6-12

D

damage
 device, 3-7
 electrostatic discharge, 3-6
 inspecting for, 1-3
 what to do, 1-3
data, recertification, 4-3
device
 cleaning, 3-8
 compatible analyzers, 1-2
 connecting, 3-9, 3-10
 damage, 3-7
 handling, 3-11
 maintenance, 1-4
 performance, verifying, 4-2
 specifications, 2-3
 certification of, 2-3
 electrical, 2-3
 environmental, 2-2
 traceability, 4-2, 4-3
 storage, 3-11
 temperature, 2-2
disk
 verification
 part number, 6-2, 6-4, 6-6,
 6-8, 6-10
documentation, part number, 6-2,
 6-6, 6-10, 6-12

E

electrical characteristics
 effects of temperature, 2-2
electrical specifications, 2-3
electrostatic discharge, *See* ESD
environmental
 regulations, 3-8
 requirements, 2-2
 specifications, 2-2
equipment required, 1-3
ESD, 3-6
 precautions, 3-6, 3-8
 protection setup, 3-6
 supplies, part numbers, 6-12

F

flange, connecting, 3-9, 3-10
flowchart, troubleshooting, 5-3

G

general information, 1-2
grounding cord, part number,
 6-12

H

handling, 3-11
heel strap
 for ESD protection, 3-6
 part number, 6-12
humidity, specifications, 2-2

I

incoming inspection, 1-3
information, troubleshooting, 5-2
inspection
 damage, 3-7
 incoming, 1-3
 mating plane surfaces, 3-7
 visual, 3-7
isopropyl alcohol
 part number, 6-12
 precautions for use of, 3-8

K

kit
 contents, 1-2, 6-3
 drawing of, 6-3
 overview, 1-2
 performance
 how Agilent verifies, 4-2

M

maintenance, 3-6
 of devices, 1-4
 preventive, 1-4
making connections, 3-10
manual part number, 6-2, 6-4,
 6-6, 6-8, 6-10
mat
 conductive, part number, 6-12
 for ESD protection, 3-6
mating plane surfaces, 3-8
 cleaning, 3-8
 inspection of, 3-7
MID-STD, 4-3
misuse of product, ii

N

National Institute of Standards
 and Technology (NIST), 2-3,
 4-2
network analyzers, compatible,
 1-2
nitrogen, for cleaning, 3-8
numbers
 replaceable parts, 6-2, 6-4, 6-6,
 6-8, 6-10
 serial, recording, 1-4

O

ordering parts, 6-2
oxygen, 3-8

P

part numbers
 included in kit, 6-2, 6-4, 6-6,
 6-8, 6-10
 not included in kit, 6-12
performance test, 4-2
performance verification, failure,
 5-2
preventive maintenance, 1-4
procedures
 cleaning, 3-8
 connections, 3-9

R

recertification
 how often, 4-3
 services included, 4-3
regulations, environmental, 3-8
relative humidity, 2-2
replaceable parts
 (Q11645A WR-22), 6-4
 (R11645A WR-28), 6-2
 (U11645A WR-19), 6-6
 (V11645A WR-15), 6-8
 (W11645A WR-10), 6-10
 drawing of, 6-3, 6-6, 6-8
report, calibration, 4-3
required equipment, 1-3
requirements, environmental, 2-2
residual errors, 2-3
return loss specifications, 2-2, 2-3
returning kit, 5-4

S

serial numbers
 devices, 1-4
 recording, 1-4
service tag, 5-4
servicing, 5-4
shipment, verifying complete, 1-3
specifications
 certification of, 2-3
 device, 2-3
 electrical, 2-3
 environmental, 2-2
 traceability, 4-2, 4-3
standard, calibration, 4-3
standards
 international, 2-3
 National Institute of Standards
 and Technology (NIST), 2-3,
 4-2

static discharge, *See* ESD

storage, 3-11
storage case, part number, 6-2,
 6-4, 6-6, 6-8, 6-10

strap

 heel and wrist, part number,
 6-12

supplies

 cleaning, 1-3
 part numbers, 6-12

T

table mat
 for ESD protection, 3-6
tag, service, 5-4
temperature
 affect on electrical performance,
 2-2
 error-corrected, 2-2
 operating, 2-2
 specifications, 2-2
 what to watch out for, 2-2
test data, 4-3
test, performance, 4-2
traceability
 of device specifications, 4-2, 4-3
troubleshooting, 5-2
 flowchart, 5-3

U

user's and service guide, 6-2, 6-4,
 6-6, 6-8, 6-10

V

verification kit
 contents, 1-2, 6-3
 drawing of, 6-3
 overview, 1-2
 performance
 how Agilent verifies, 4-2
 warranty, ii
verification, failure, 5-2
visual inspection, 3-7

W

warranty, ii
waveguide, connecting, 3-9
wear, connector, 3-7
 affect on electrical performance,
 3-7
wrist strap
 for ESD protection, 3-6
 part number, 6-12